

# PRODUCT INFORMATION PACKET

Model No: 145THTN19058  
Catalog No: W513A  
2 HP Severe Duty Motor, 3 phase, 1800 RPM, 460 V, 145T Frame, TENV  
IEEE 841 Motors





### Nameplate Specifications

Output HP	<b>2 Hp</b>	Output KW	<b>1.5 kW</b>
Frequency	<b>60 Hz</b>	Voltage	<b>460 V</b>
Current	<b>3.0 A</b>	Speed	<b>1740 rpm</b>
Service Factor	<b>1.15</b>	Phase	<b>3</b>
Efficiency	<b>86.5 %</b>	Power Factor	<b>78</b>
Duty	<b>Continuous</b>	Insulation Class	<b>F</b>
Design Code	<b>B</b>	KVA Code	<b>N</b>
Frame	<b>145T</b>	Enclosure	<b>Totally Enclosed Non Ventilated</b>
Thermal Protection	<b>No</b>	Ambient Temperature	<b>40 °C</b>
Drive End Bearing Size	<b>6205</b>	Opp Drive End Bearing Size	<b>6203</b>
UL	<b>Recognized</b>	CSA	<b>Y</b>
CE	<b>Y</b>	IP Code	<b>56</b>
Hazardous Location	<b>DIVISION 2 T2B</b>		

### Technical Specifications

Electrical Type	<b>Squirrel Cage Inverter Rated</b>	Starting Method	<b>Line Or Inverter</b>
Poles	<b>4</b>	Rotation	<b>Reversible</b>
Resistance Main	<b>6.51 Ohms</b>	Mounting	<b>Rigid Base</b>
Motor Orientation	<b>Horizontal</b>	Drive End Bearing	<b>Ball</b>
Opp Drive End Bearing	<b>Ball</b>	Frame Material	<b>Cast Iron</b>
Shaft Type	<b>T</b>	Overall Length	<b>11.43 in</b>
Frame Length	<b>6.25 in</b>	Shaft Diameter	<b>0.875 in</b>
Shaft Extension	<b>2.56 in</b>	Assembly/Box Mounting	<b>F1/F2 CAPABLE</b>
Connection Drawing	<b>EE7300</b>	Outline Drawing	<b>104326-625</b>

This is an uncontrolled document once printed or downloaded and is subject to change without notice. Date Created:19/10/2020



**THREE PHASE - SINGLE VOLTAGE  
MOTOR - CONDUIT BOX @ 'A'**

**TO REVERSE ROTATION:  
INTERCHANGE ANY TWO  
LINE LEAD CONNECTIONS.**

**TERMINAL BLOCK WHEN SPECIFIED**



**VIEW OF TERMINAL END**

**IF MOTOR HAS  
6 LEADS**

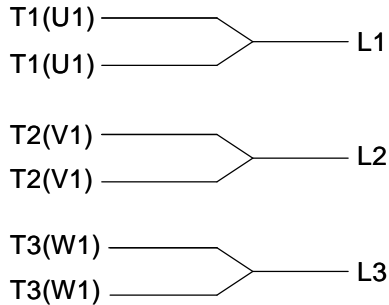

**A-9806 DECAL**

**OPTIONAL CORD  
CONNECTION**



DRAWING REVISION <b>AB</b>	REVISION BY <b>JJB</b>	DATE <b>06-27-2017</b>
ECO <b>ECO-0125361</b>	APPROVED BY <b>TB</b>	DATE <b>06-27-2017</b>
ECO DESCRIPTION <b>UPDATED TO CURRENT STANDARDS</b>		
<small>COPYRIGHT REGAL BELOIT AMERICA, INC. ALL RIGHTS RESERVED.                  PROPRIETARY AND CONFIDENTIAL INFORMATION - THIS DOCUMENT IS THE PROPERTY OF                  REGAL BELOIT AMERICA, INC. ("OWNER") AND CONTAINS OWNER'S PROPRIETARY                  INFORMATION. ANY PERSON, CORPORATION OR OTHER FIRM RECEIVING IT IS DEEMED,                  BY RECEIVING IT, TO AGREE THAT IT, AND/OR ANY PART OF IT, SHALL NOT BE DISCLOSED                  TO ANY PERSON, CORPORATION OR OTHER ENTITY, DUPLICATED, AND/OR USED, EXCEPT                  AS EXPRESSLY APPROVED IN WRITING IN ADVANCE BY OWNER. THIS DOCUMENT SHALL                  BE RETURNED TO OWNER UPON REQUEST. IT MAY BE SUBJECT TO CERTAIN                  RESTRICTIONS UNDER APPLICABLE EXPORT CONTROL LAWS AND REGULATIONS.</small>		



DRAWN BY <b>DA</b>
DATE <b>03-26-1993</b>
APPROVED BY <b>TB</b>
DATE <b>03-26-1993</b>
REFERENCE
THIRD ANGLE PROJECTION

<b>Regal Beloit America, Inc.</b>	
DESCRIPTION <b>CONNECTION DIAGRAM EXTERNAL - SINGLE VOLTAGE - 3Ø MOTOR</b>	
MATERIAL	PROCESS/FINISH
SIZE <b>A</b>	DRAWING NUMBER <b>EE7300</b>
SHEET <b>1 OF 1</b>	



